

# ANTO L1014

Parklampe / Post lights / Mastleuchte / Lyktstolper

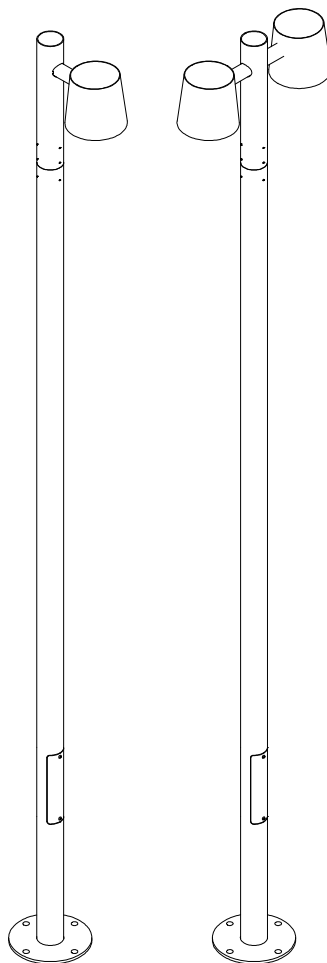

Monteringsvejledning / Mounting instructions /  
Installationsanleitung / Installationsinstruktioner

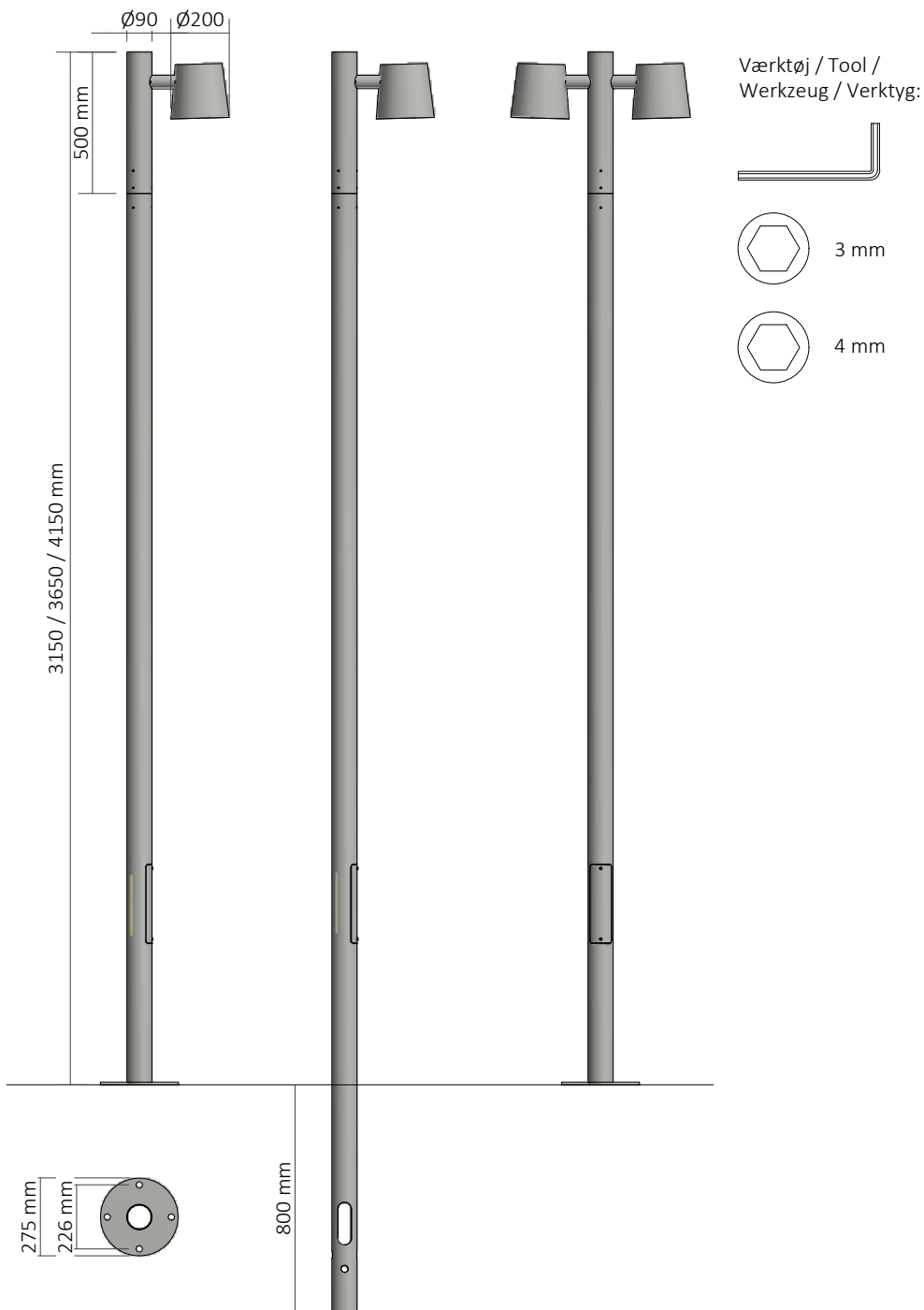

1



4 mm

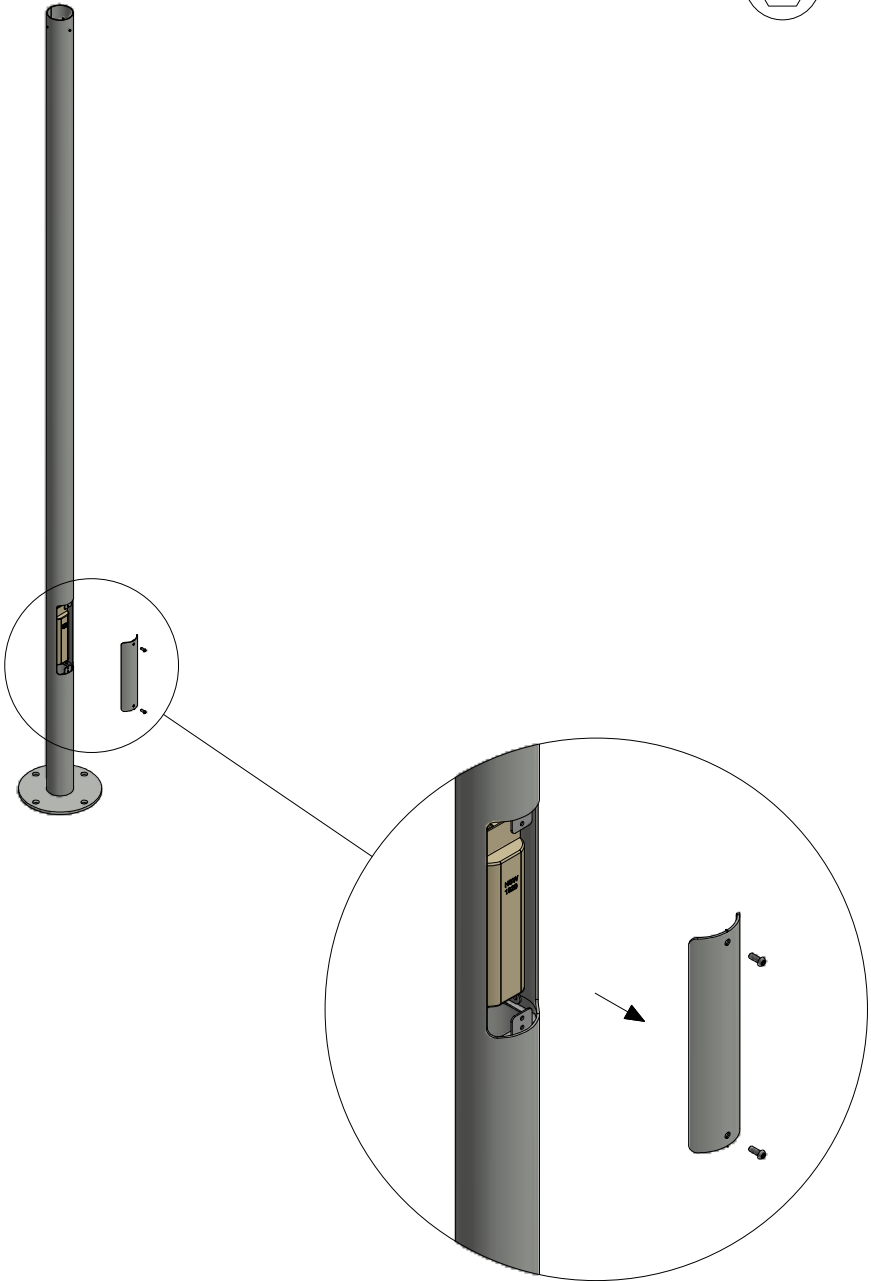

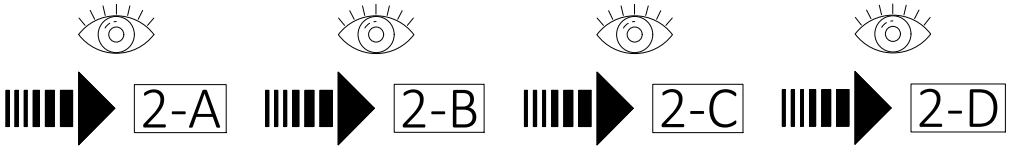

2-A

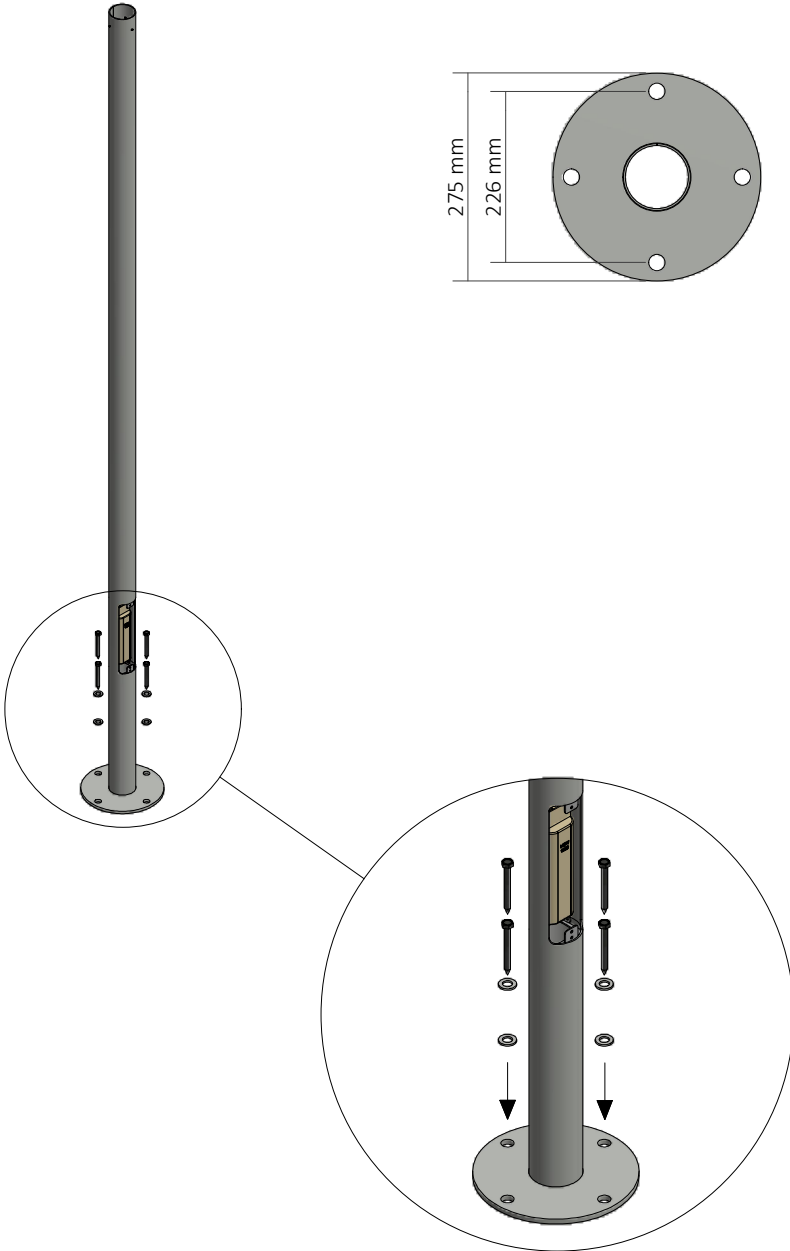

2-B

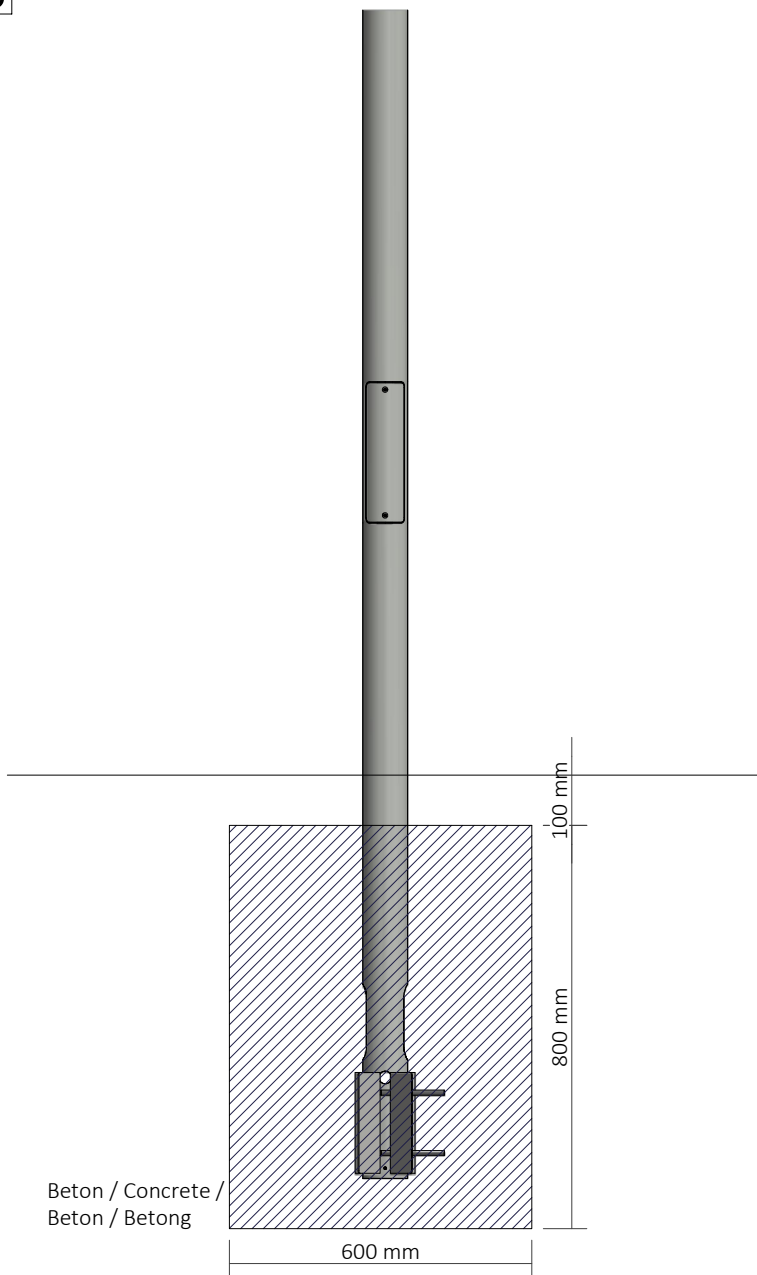

Se monteringsvejledning / See mounting instructions / Siehe  
Installationsanleitung / Se Installationsinstruktioner nr. 19651000-96

2-C

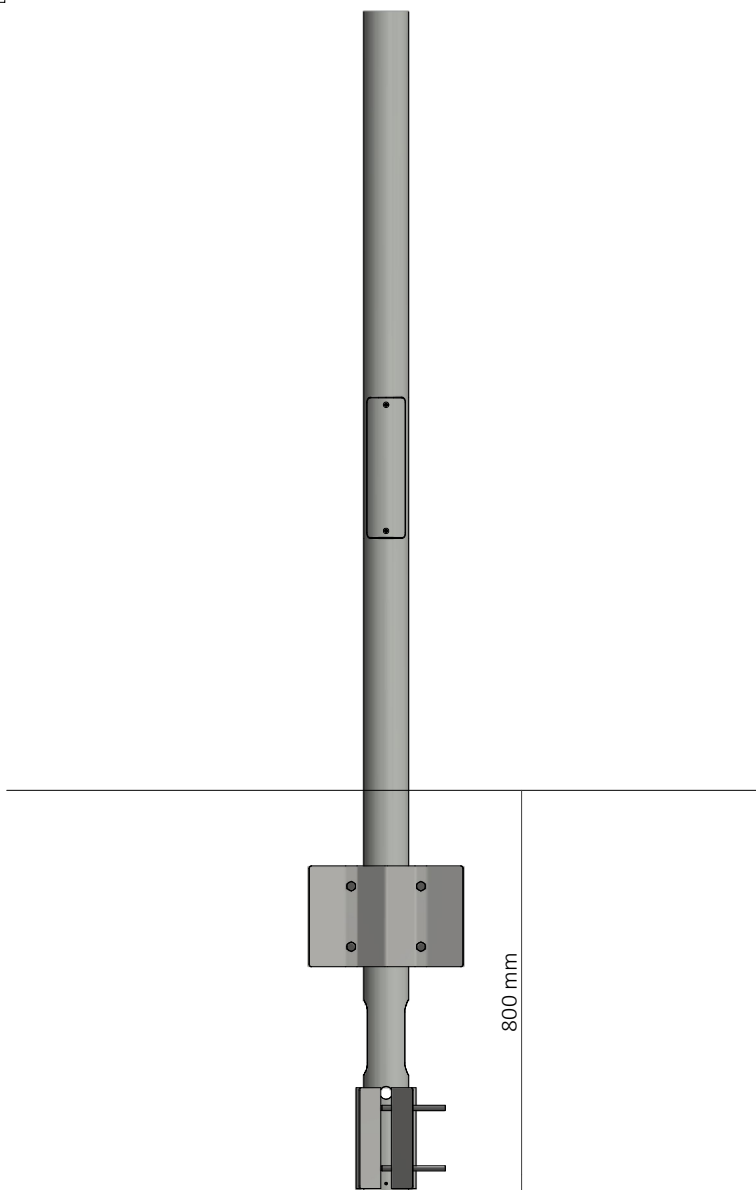

Se monteringsvejledning / See mounting instructions / Siehe  
Installationsanleitung / Se Installationsinstruktioner nr. 19651000-96

2-D

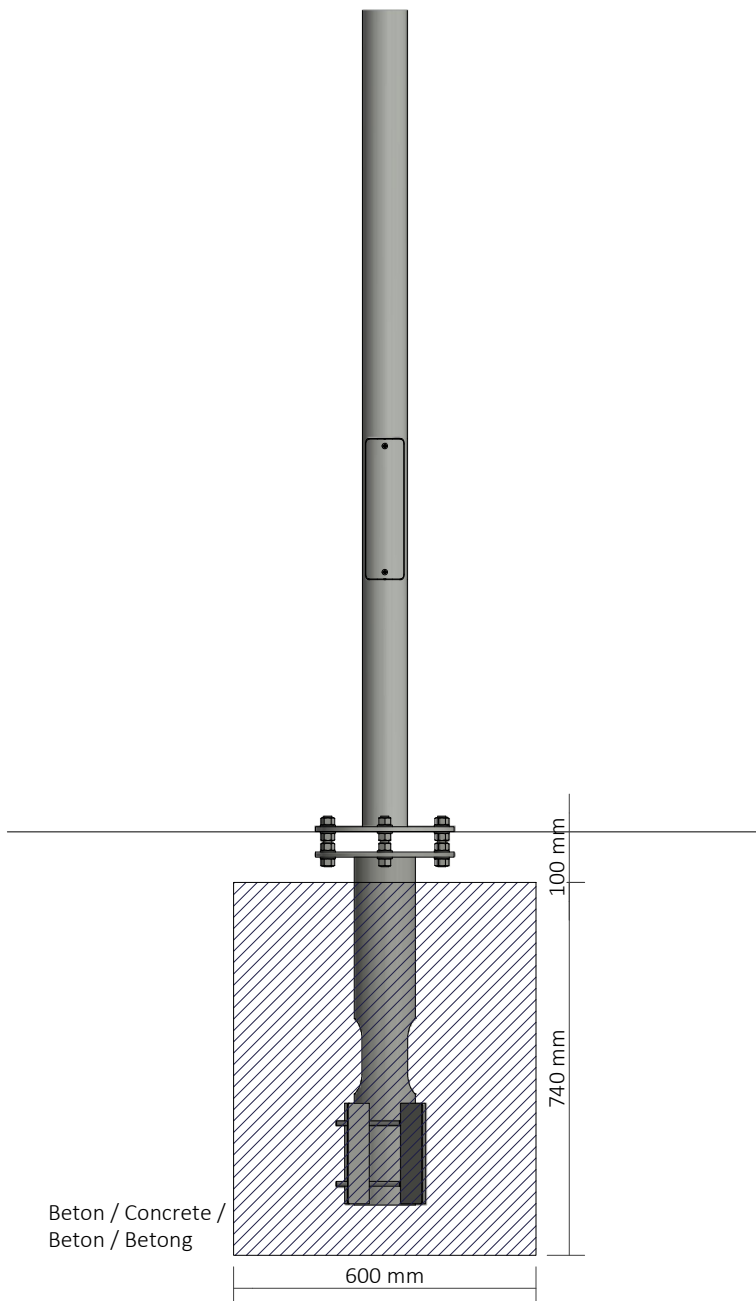

Se monteringsvejledning / See mounting instructions / Siehe  
Installationsanleitung / Se Installationsinstruktioner nr. 19651000-95



3



3 mm

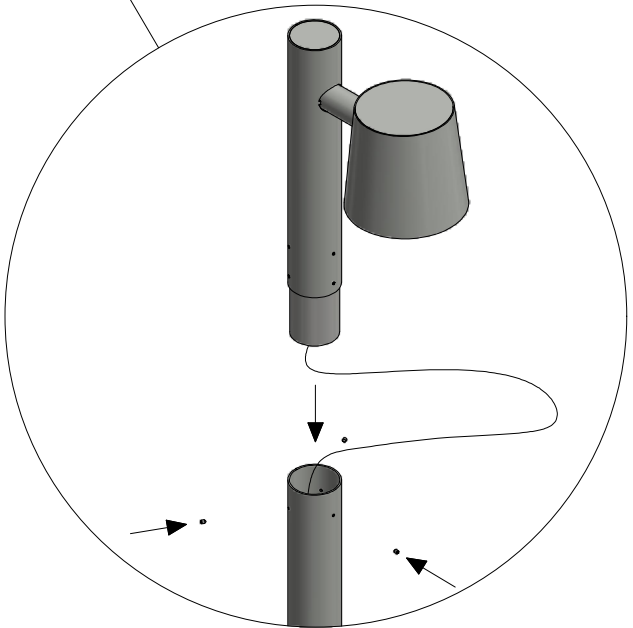
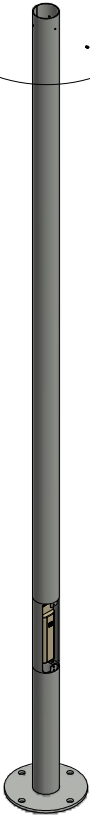
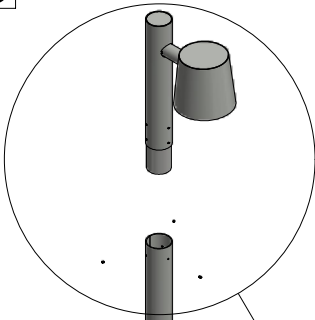

4

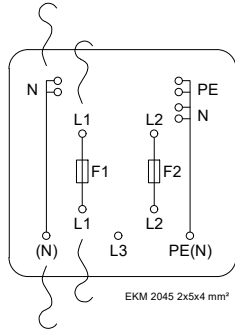
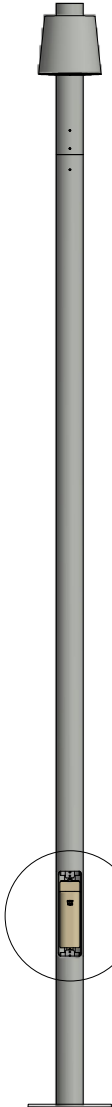



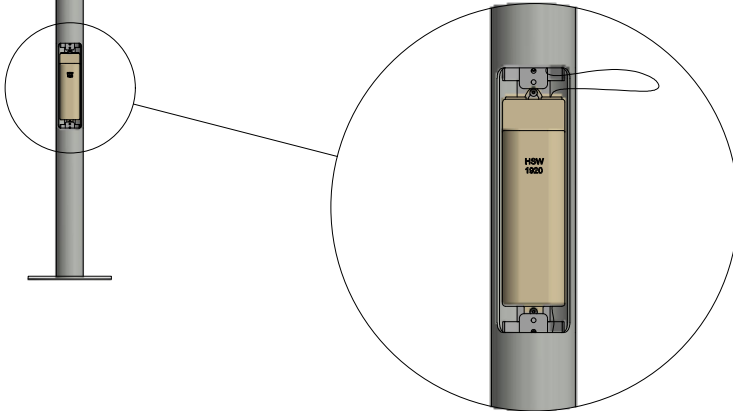





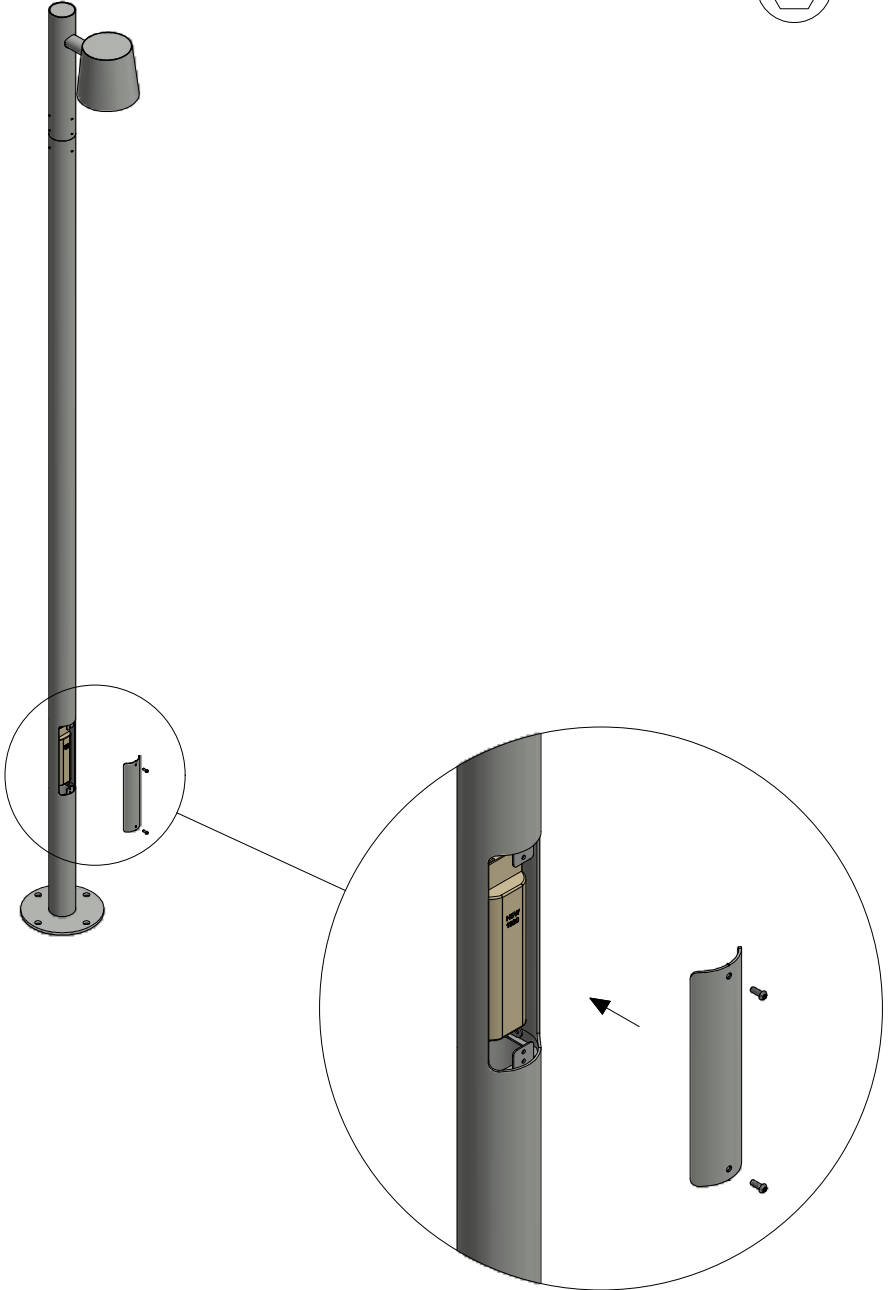

Isolationsklasse II / Insulation class II /  
Schutzklasse II / Isolationsklass II



5

 4 mm



				
	LED			
	Isolationsklasse II / Insulation class II / Schutzklasse II / Isolationsklass II			
	IP56			
IK	IK10			
	41 / 46 / 51 kg			
	Se vedligeholdelses vejledning / See maintenance instructions / Siehe Wartungsanweisungen / Se underhållsinstruktioner			
	Montering/udskiftning må kun udføres af producenten eller aut. el-installatør / Installation/replacement must only be carried out by the manufacturer or by an electrician / Die Installation/der Austausch darf nur vom Hersteller oder von einem Elektriker durchgeführt werden / Installation / utbyte får endast utföras av tillverkaren eller av en behörig elektriker			