

OCO L1500

Pullert / Bollard / Poller / Pollare

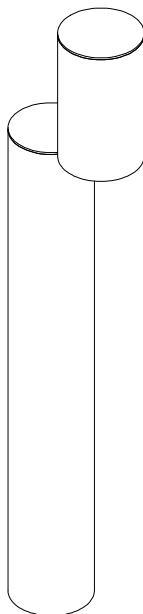

Monteringsvejledning / Mounting instructions /
Installationsanleitung / Installationsinstruktioner

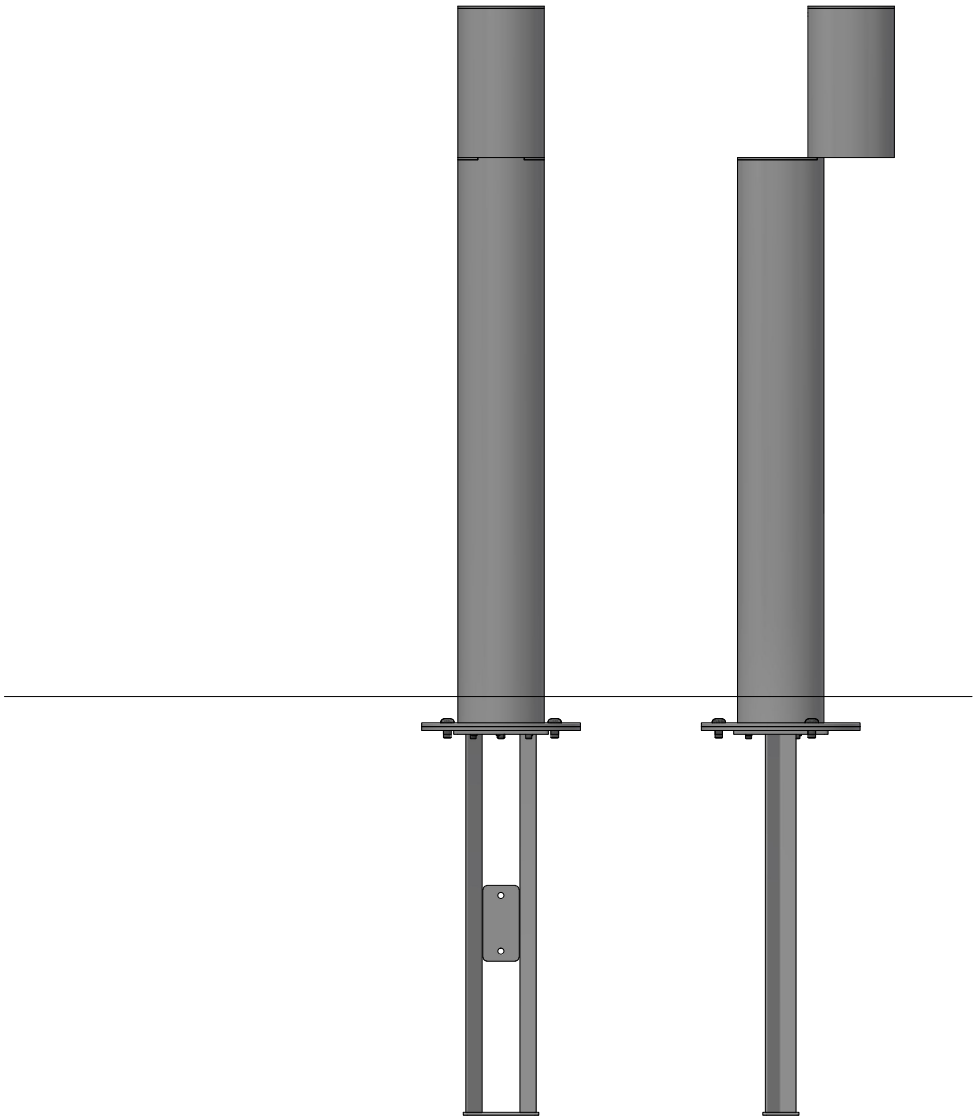

Værktøj / Tool / Werkzeug / Verktug:



10 mm



8 mm



1

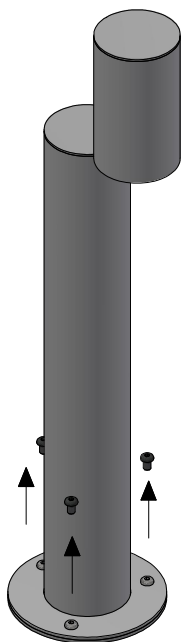

10 mm

2

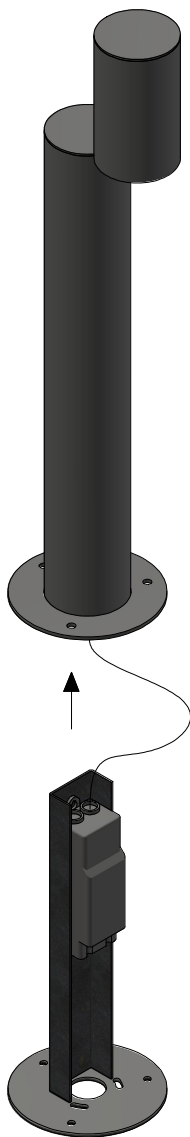

3-A

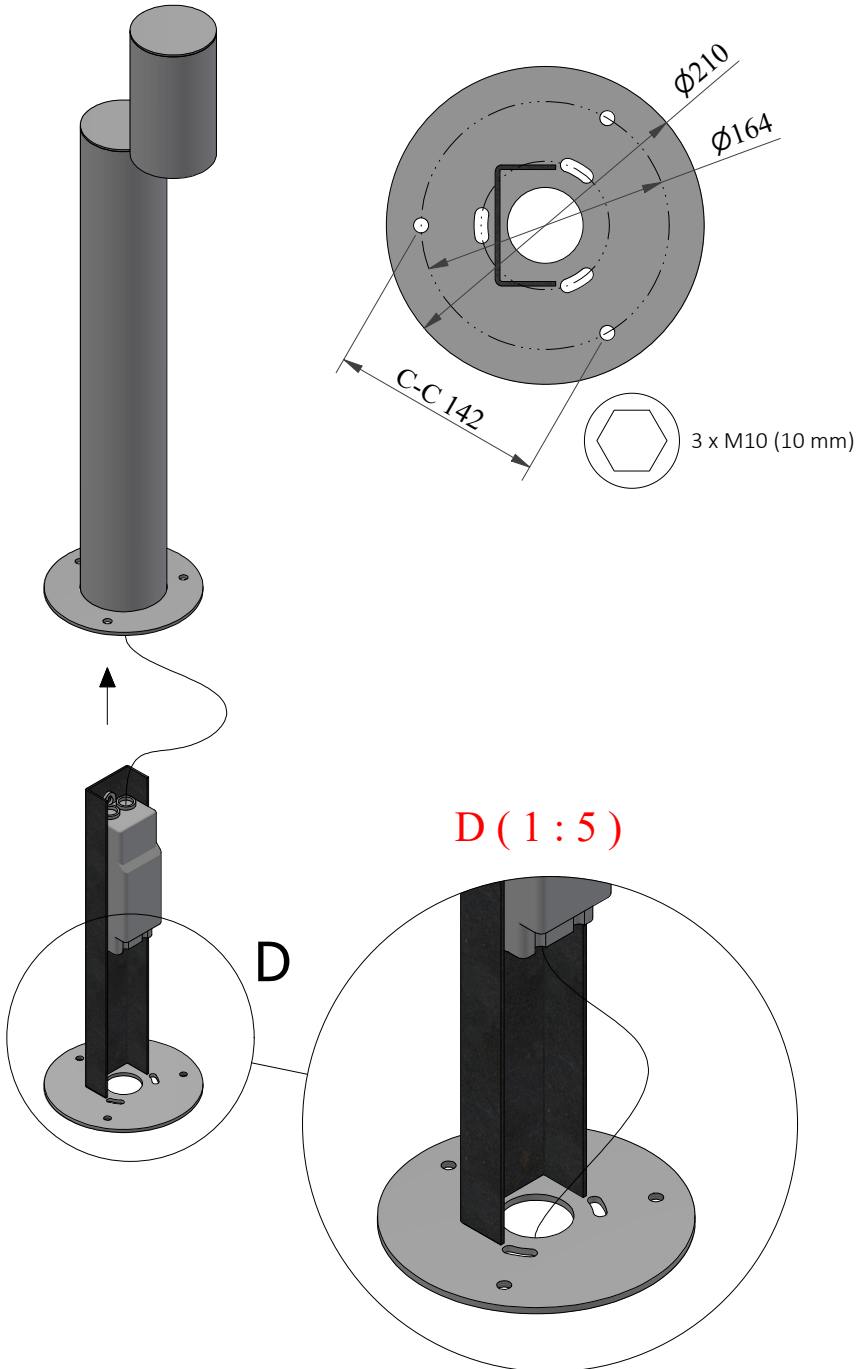

3-B

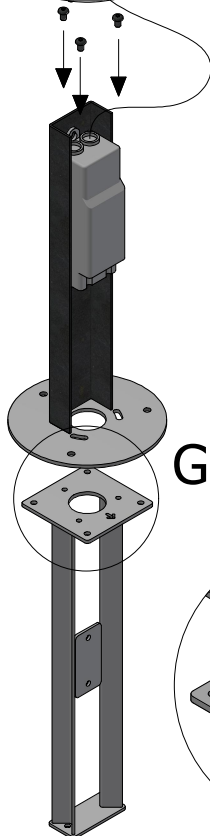
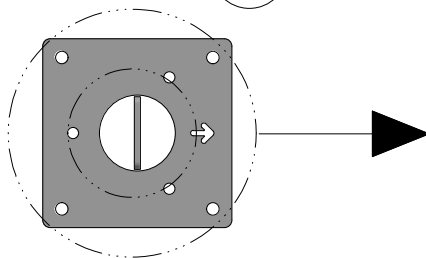
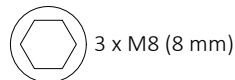
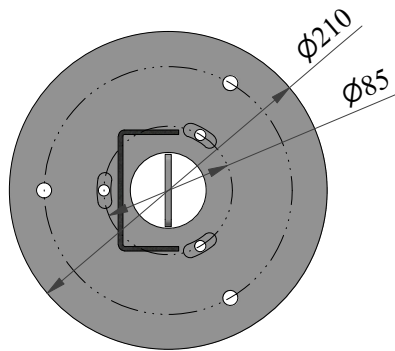
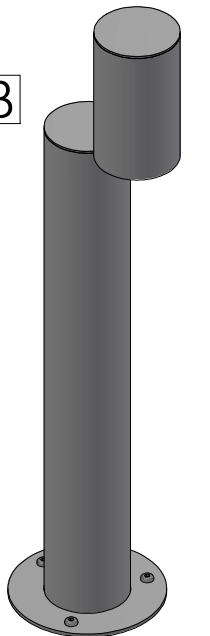

G

G (1:5)

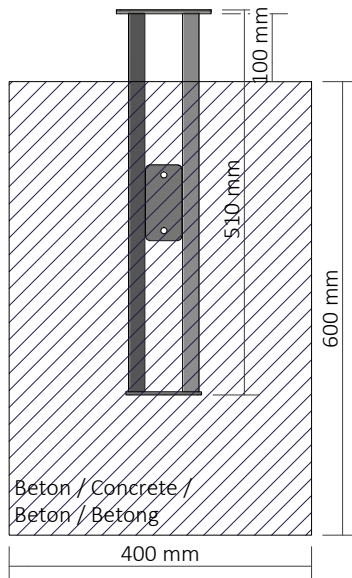
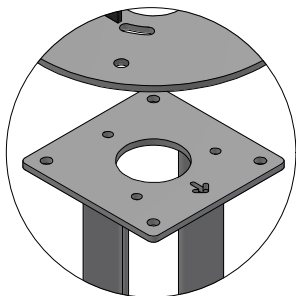

4

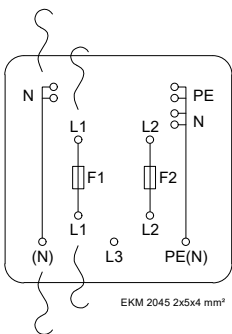
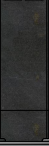
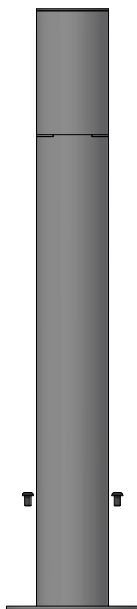

Isolationsklasse II / Insulation class II /
Schutzklasse II / Isolationsklass II

5

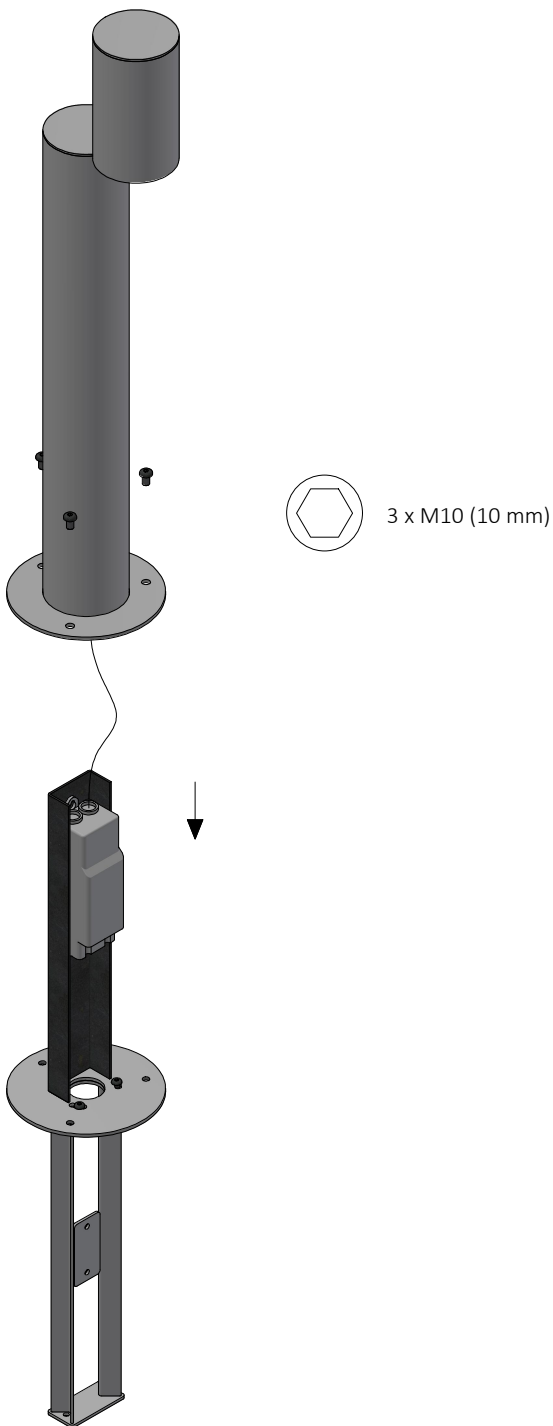



LED



220-240 V 50-60 Hz



Isolationsklasse II / Insulation class II / Schutzklasse II / Isolationsklass II



IP66

IK

IK10



13,7 kg



Se vedligeholdelses vejledning / See maintenance instructions /
Siehe Wartungsanweisungen / Se underhållsinstruktioner

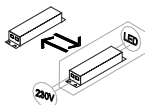

Montering samt udskiftning af lyskilde eller driver må kun udføres af
producenten eller aut. el-installatør /
Installation and replacement of the light source or driver may only be
carried out by the manufacturer or by an authorised electrician /
Die Installation und Austausch der Lichtquelle oder des Treibers darf nur
vom Hersteller oder einem autorisierten Elektriker durchgeführt werden /
Installation och utbyte av ljuskälla eller drivdon får endast utföras av
tillverkaren eller en auktoriserad elektriker.



Dette produkt indeholder en lyskilde i energieffektivitetsklasse: /
This product contains a light source of energy efficiency class: /
Dieses Produkt enthält eine Lichtquelle der Energieeffizienzklasse: /
Denna produkt innehåller en ljuskälla med energieffektivitetsklass:

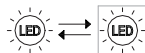

Luminaire	CCT	Energy Efficiency Class
Fortimo FastFlex 2x2 DA HE	CCT 2200, CRI 70	D
Fortimo FastFlex 2x2 DA HE	CCT 2700, CRI 70	D
Fortimo FastFlex 2x2 DA gen.5	CCT 3000, CRI 70	D
Fortimo FastFlex 2x2 DA gen.5	CCT 4000, CRI 70	D

Lampas